

TECHNICAL SPECIFICATIONS		
ZIG ZAG 20		
Potenza disponibile / Available powers		Up to 13 kW
Ingombri / Overall dimensions		
A (lungh.mm/lenght inch)	B (largh.mm/widht inch)	C (alt.mm/height inch)
1750 / 68.9	1100 / 43.3	3700 / 145.7
ZIG ZAG 30		
Potenza disponibile / Available powers		Up to 16.5 kW
Ingombri / Overall dimensions		
A (lungh.mm/lenght inch)	B (largh.mm/widht inch)	C (alt.mm/height inch)
2100 / 82.7	1100 / 43.3	4000 / 157.5
ZIG ZAG 40		
Potenza disponibile / Available powers		Up to 23.5 kW
A (lungh.mm/lenght inch)	B (largh.mm/widht inch)	C (alt.mm/height inch)
2200 / 86.6	1100 / 43.3	5500 / 216.5

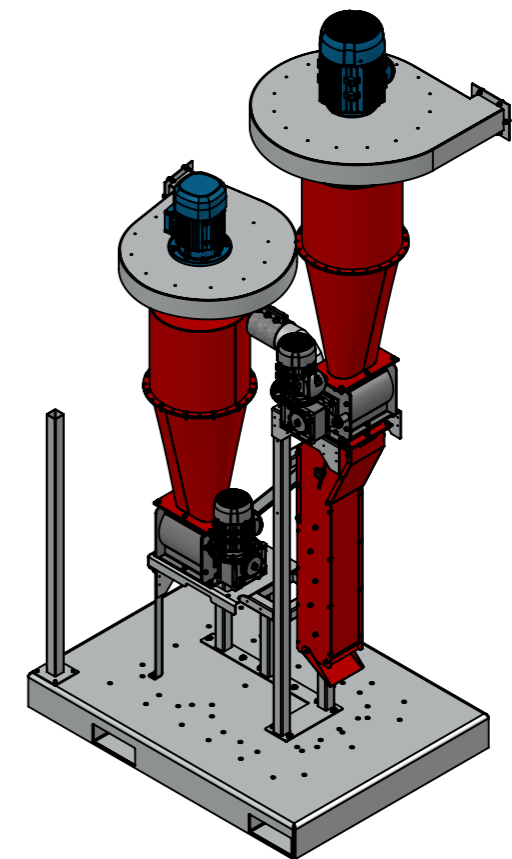

Via E. Rossaro, 7 - 44012 Bondeno (FE)
 Tel. +39 (0)532 897664
 Fax +39 (0)532 891270
 www.mgrecycling.it e-mail:info@mgrecycling.it

DESCRIPTION		DATE	
TECHNICAL SHEET ZIG ZAG 20/30/40			
NOTES	SHEET	SCALE	WEIGHT (kg)
	1/1		
DISIGNER	FORMAT	DRAWING CODE	REVIEW
	A3		-
ANY DRAWING OR TECHNICAL DOCUMENT RELATING TO OUR PRODUCTS, EVEN IF RETURNED TO THE CLIENT, IS ALWAYS EXCLUSIVE PROPERTY OF MG RECYCLING srl, AND CANNOT BE USED BY THE CLIENT, COPIED, REPRODUCED, TRANSMITTED OR COMMUNICATED TO THIRD PARTY WITHOUT OUR PRIOR WRITTEN AUTHORISATION.			