

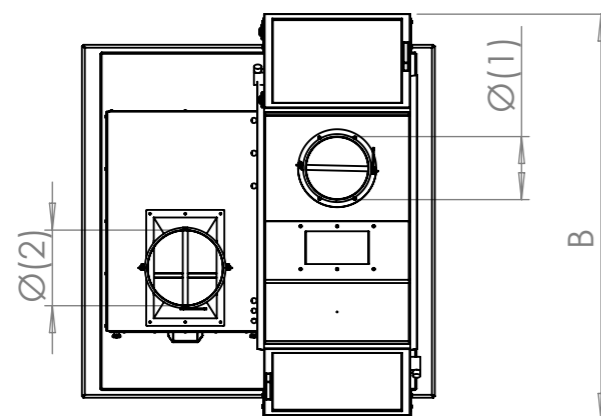

Specifiche Tecniche / Technical Specifications

Separatore Separator	Dimensioni Massime [mm] Overall dimensions [Inch]			Potenze Disponibili Available Powers [kW]	Dim. Tavola vibrante [mm] Vibrating Table Dim. [Inch]	Ø Tubo Asp. Polvere [mm] Ø Dust Suction Pipe [Inch] (1)	Ø Tubo Asp. Aria pulita [mm] Ø Clean Air Pipe [Inch] (2)	Produzione in Ingresso (fino a) Input Production (up to)	
	A	B	C					Kg/h	Lb/h
SP150Vi	1100 / 43.3	1350 / 53.1	1900 / 74.8	1 kW	190x800 / 7.5x31.5	150 / 5.9	200 / 7.9	250	550
SP150VPi	1100 / 43.3	1350 / 53.1	1900 / 74.8	0.6 kW	190x800 / 7.5x31.5	150 / 5.9	200 / 7.9	250	550
SP220Vi	1100 / 43.3	1350 / 53.1	1900 / 74.8	1.4 kW	260x800 / 10.3x31.5	200 / 7.9	250 / 9.9	500	1100
SP220VPi	1100 / 43.3	1350 / 53.1	1900 / 74.8	0.6 kW	260x800 / 10.3x31.5	200 / 7.9	250 / 9.9	500	1100
SP380Vi	1400 / 55.1	1600 / 63.0	2000 / 78.7	2.44 kW	420x1100 / 16.5x43.3	250 / 9.9	300 / 11.8	1000	2200
SP380VPi	1400 / 55.1	1600 / 63.0	2000 / 78.7	1.75 kW	420x1100 / 16.5x43.3	250 / 9.9	300 / 11.8	1000	2200
SP610Vi	1660 / 65.4	1800 / 70.8	2085 / 82.1	3.38 kW	650x1250 / 25.6x49.2	300 / 11.8	400 / 15.8	2000	4400
SP610VPi	1660 / 65.4	1800 / 70.8	2085 / 82.1	2.5 kW	650x1250 / 25.6x49.2	300 / 11.8	400 / 15.8	2000	4400
SP750Vi	1870 / 73.6	1800 / 70.8	2085 / 82.1	4.38 kW	790x1250 / 31.1x49.2	300 / 11.8	400 / 15.8	3000	6600
SP1000Vi	2100 / 82.7	2050 / 80.7	2280 / 89.8	6.2 kW	990x1500 / 39x59.1	350 / 13.8	500 / 19.7	4000	8800

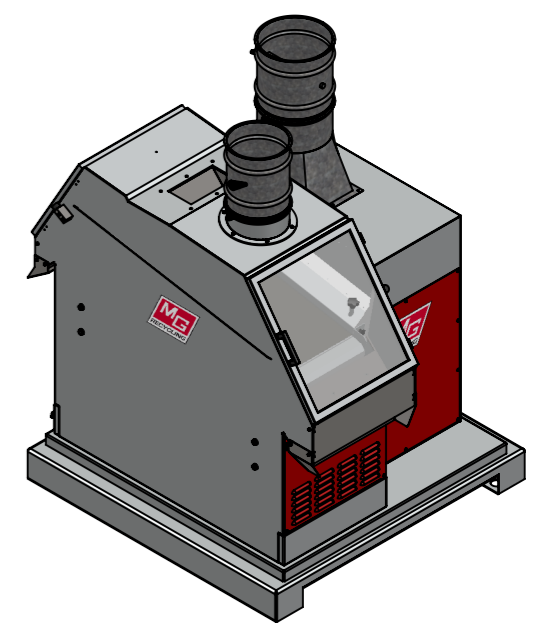
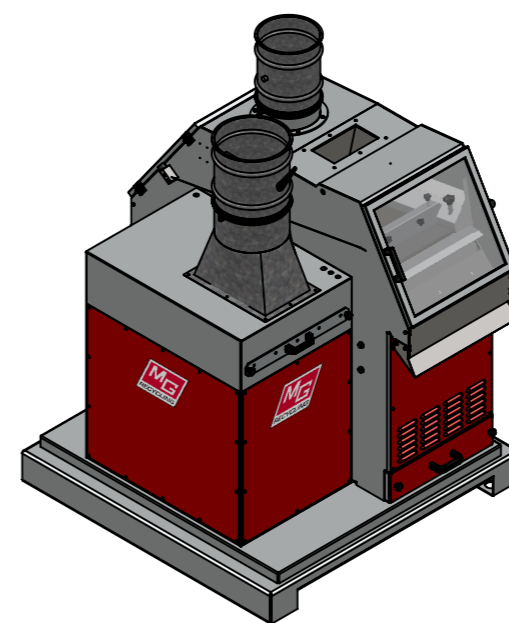
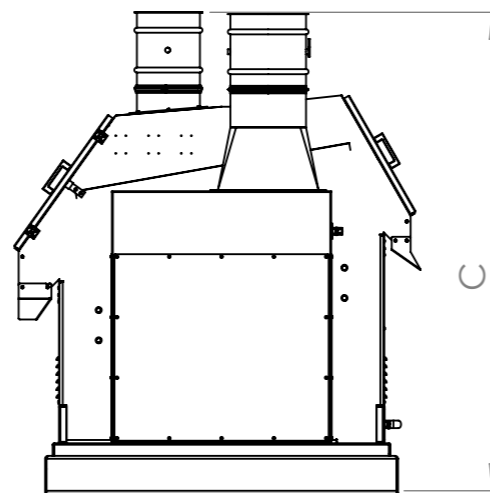
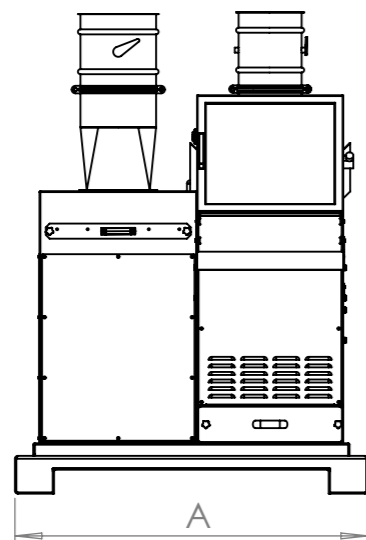

 <p>Via E. Rossaro, 7 - 44012 Bondeno (FE) Tel. +39(0)532 897664 Fax +39(0)532 891270 www.mgrecycling.it e-mail:info@mgrecycling.it</p>	DESCRIPTION SEPARATORS TECHNICAL SHEET		DATE	
	NOTES	SHEET 1/1	SCALE	WEIGHT (kg) -
	DISIGNER	FORMAT A3	DRAWING CODE	REVIEW
	ANY DRAWING OR TECHNICAL DOCUMENT RELATING TO OUR PRODUCTS, EVEN IF RETURNED TO THE CLIENT, IS ALWAYS EXCLUSIVE PROPERTY OF MG RECYCLING s.r.l. AND CANNOT BE USED BY THE CLIENT, COPIED, REPRODUCED, TRANSMITTED OR COMMUNICATED TO THIRD PARTY WITHOUT OUR PRIOR WRITTEN AUTHORISATION.			